



## KEYBOARD CONTROLLER

### GENERAL DESCRIPTION

The W83C43 is a keyboard controller designed to provide the functions needed to interface a CPU to a keyboard or to a PS/2 mouse. The W83C43 can be used with IBM®-compatible personal computers or PS/2-based systems. The controller receives serial data from the keyboard or PS/2 mouse, checks the parity of the data, and presents the data to the system as a byte of data in its output buffer. The controller will interrupt the system when data are placed in its output buffer. The keyboard and PS/2 mouse are required to acknowledge all data transmissions. No transmission should be sent to the keyboard or PS/2 mouse until acknowledge is received for the previous byte sent.

This fast keyboard controller can improve the performance of IBM PC/AT® 386™ DX/SX and 486™ DX/SX machines and their compatibles. Hardwire methodology is used in this controller instead of software implementation, as in the traditional 8042 keyboard BIOS. With full hardware implementation, this enables the keyboard controller to respond instantly to all commands sent from the keyboard and PS/2 mouse to the CPU BIOS.

The keyboard controller enables popular programs such as AutoCAD®, Microsoft® Windows™ 3.1, NOVELL®, and other programs to run much faster.

### FEATURES

- Supports IBM PC/AT 386 DX/SX and 486 DX/SX system designs
- Full hardwire design based on advanced VLSI CMOS technology
- Supports PS/2 Mouse
- 6 MHz to 12 MHz operating frequency
- Supports AT mode and PS/2 mode for different hardware configurations
- Automatically detects PS/2 mode or AT mode
- Much faster than traditional keyboard controller
- Packaged in 40-pin DIP or 44-pin PLCC

## PIN CONFIGURATIONS

### 40-pin DIP

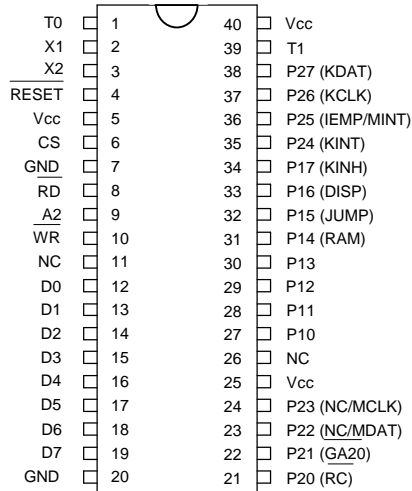

### 44-pin PLCC

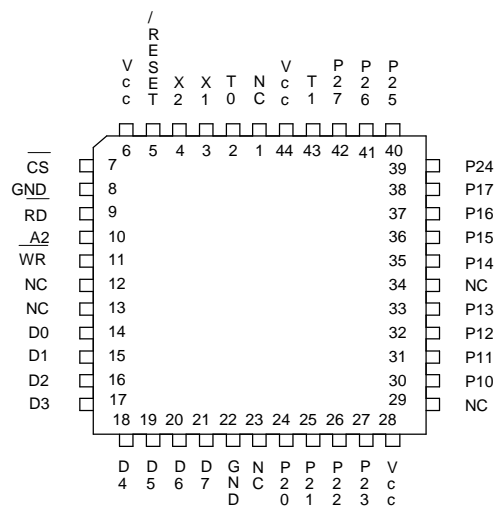



## PIN DESCRIPTION

PIN NO.		I/O	NAME	FUNCTION	
(40-pin DIP)	(44-pin PLCC)			AT MODE	PS/2 MODE
1	2	I	T0	K/B Clock Input	K/B Clock Input
2	3	I	X1	Crystal Clock I/P	Crystal Clock I/P
3	4	I	X2	Crystal Clock I/P	Crystal Clock I/P
4	5	I	$\overline{\text{RESET}}$	Chip Reset	Chip Reset
5	6	-	Vcc	Optional +5V Power Supply	Optional + 5V Power Supply
6	7	I	$\overline{\text{CS}}$	Chip Select	Chip Select
7	8	-	GND	Optional Ground Power	Optional Ground Power
8	9	I	$\overline{\text{RD}}$	I/O Read	I/O Read
9	10	I	A2	Connect to Address A2	Connect to Address A2
10	11	I	$\overline{\text{WR}}$	I/O Write	I/O Write
11, 26	1, 12, 13, 23, 29, 34	-	NC	Reserved	Reserved
12, 13, 14, 15, 16, 17, 18, 19	14, 15, 16, 17, 18, 19, 20, 21	I/O	D0–D7	Data Bus D0–D7	Data Bus D0–D7
20	22	-	GND	Ground Power Supply	Ground Power Supply
21	24	O	P20	Bit 0 of Port2 ( $\overline{\text{RC}}$ : System Reset)	Bit 0 of Port2 ( $\overline{\text{RC}}$ : System Reset)
22	25	O	P21	Bit 1 of Port2 ( $\overline{\text{GA20}}$ : GATE A20)	Bit 1 of Port2 ( $\overline{\text{GA20}}$ : GATE A20)
23	26	I/O	P22	Bit 2 of Port2 (NC: User-defined I/O)	Bit 2 of Port2 (MDAT: Mouse Data Output)
24	27	I/O	P23	Bit 3 of Port2 (NC: User-defined I/O)	Bit 3 of Port2 (MCLK: Mouse Clock Output)
25	28	-	Vcc	Optional +5V Power Supply	Optional + 5V Power Supply



Pin Description, continued

PIN NO.		I/O	NAME	FUNCTION	
(40-pin DIP)	(44-pin PLCC)			AT MODE	PS/2 MODE
27	30	I/O PU*	P10	Bit 0 of Port1 (User-defined I/O)	Bit 0 of Port1 (K/B Data Input)
28	31	I/O PU*	P11	Bit 1 of Port1 (User-defined I/O)	Bit 1 of Port1 (Mouse Data Input)
29	32	I/O	P12	Bit 2 of Port2 (User-defined I/O)	Bit 2 of Port2 (User-defined I/O)
30	33	I/O	P13	Bit 3 of Port1 (User-defined I/O)	Bit 3 of Port1 (User-defined I/O)
31	35	I PU*	P14	Bit 4 of Port1 (RAM: RAM Jumper Select)	Bit 4 of Port1 (RAM: RAM Jumper Select)
32	36	I PU*	P15	Bit 5 of Port1 (JUMP: Jumper)	Bit 5 of Port1 (JUMP: Jumper)
33	37	I PU*	P16	Bit 6 of Port1 (DISP: Display Select)	Bit 6 of Port1 (DISP: Display Select)
34	38	I PU*	P17	Bit 7 of Port1 (KINH: K/B Inhibit Switch)	Bit 7 of Port1 (KINH: K/B Inhibit Switch)
35	39	O	P24	Bit 4 of Port2 (KINT: K/B OBF O/P Interrupt)	Bit 4 of Port2 (KINT: K/B OBF O/P Interrupt)
36	40	O	P25	Bit 5 of Port2 (IEMP: I/P Buffer Empty)	Bit 5 of Port2 (MINT: Mouse OBF O/P Interrupt)
37	41	O	P26	Bit 6 of Port2 (KCLK: K/B Clock Output)	Bit 6 of Port2 (KCLK: K/B Clock Output)
38	42	O	P27	Bit 7 of Port2 (KDAT: K/B Data Output)	Bit 7 of Port2 (KDAT: K/B Data Output)
39	43	I	T1	K/B Data Input	Mouse Clock Input
40	44	-	Vcc	+5V Power Supply	+5V Power Supply

\* Internal pull-up resistor



## BLOCK DIAGRAM

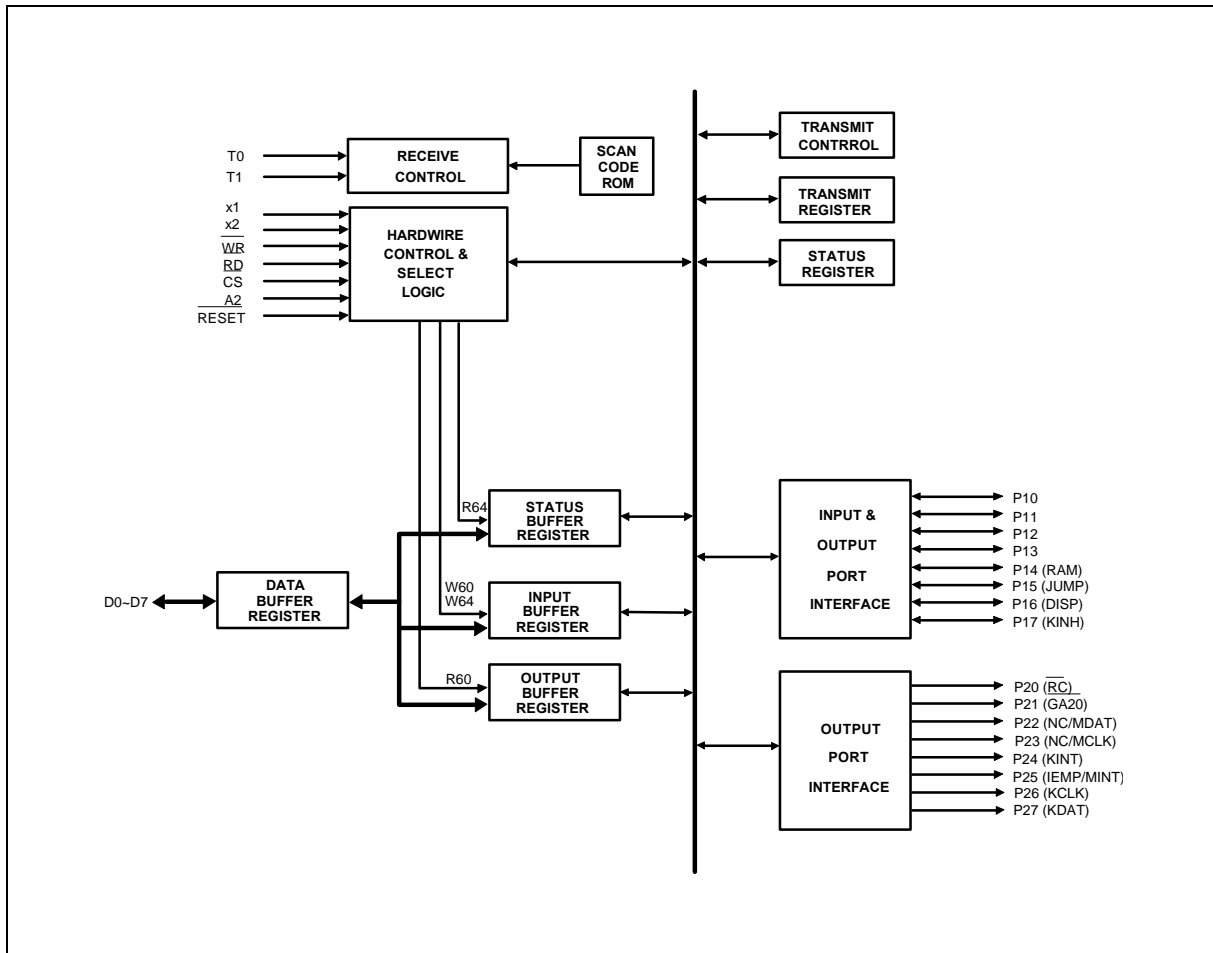

## ABSOLUTE MAXIMUM RATINGS

PARAMETER	RATING	UNIT
Ambient Operating Temperature	-0 to + 85	°C
Storage Temperature	-65 to + 150	°C
Supply Voltage to Ground Potential	-0.3 to + 7.0	V
Applied Input/Output Voltage	-0.3 to + 7.0	V
Power Dissipation	50	mW

Note: Exposure to conditions beyond those listed under Absolute Maximum Ratings may adversely affect the life and reliability of the device.



## ELECTRICAL CHARACTERISTICS & CAPACITANCE

(Ta = 0° C to +70° C, VDD = +5V ± 5%)

SYMBOL	DESCRIPTION	MIN.	TYP.	MAX.	UNIT	NOTE
VDD	Power Supply	4.75	5.0	5.25	V	
VIL	Input Low Voltage (except RESET, T0, T1)			0.8	V	
VIL1	Input Low Voltage (RESET, T0, T1)			0.6	V	
VIH1	Input High Voltage (except RESET, T0, T1, P10, P11)	2.0			V	
VIH2	Input High Voltage (P10, P11)	3.0			V	
VIH3	Input High Voltage (T0, T1, RESET)	3.5			V	
VOH1	Output High Voltage (P10–P13, P20–P27)			2.4	V	IOH = -2 mA
VOH2	Output High Voltage (D0–D7)			2.4	V	IOH = -4 mA
VOL1	Output Low Voltage (P10–P13, P20–P27)	0.4			V	IOL = 2 mA
VOL2	Output Low Voltage (D0–D7)	0.4			V	IOL = 4 mA
RIP	Min. I/P Resist	10K			Ω	
IOFL	O/P Leakage Current (D0–D7, High Z State)	-10		10	μA	
IiH	I/P Leakage Current	-10		10	μA	VDD = 5.5V, VIN = VDD
IiL	I/P Leakage Current (Except P10, P11, P14, P15, P16, P17)	-10		10	μA	VDD = 5.5V, VIN = VSS
IiL1	I/P Leakage Current (P10, P11, P14, P15, P16, P17)	-10		550	μA	VDD = 5.5V, VIN = VSS
CL	O/P Load Capacity	15		50	pF	

### STATUS REGISTER (AT MODE)

The status register is an 8-bit read-only register at I/O address hex 64 that holds information about the status of the keyboard controller and interface. It may be read at any time.

BIT	BIT FUNCTION	DESCRIPTION
0	Output Buffer Full	0: Output buffer empty 1: Output buffer full
1	Input Buffer Full	0: Input buffer empty 1: Input buffer full



Status Register (AT Mode), continued

BIT	BIT FUNCTION	DESCRIPTION
2	System Flag	This bit may be set to 0 or 1 by writing to the system flag bit in the command byte of the keyboard controller. It is set to 0 after a power-on reset
3	Command/data	0: Data byte 1: Command byte
4	Inhibit Switch	0: Keyboard is inhibited 1: Keyboard is not inhibited
5	Transmit Time-out	0: No transmit time-out error 1: Transmit time-out error
6	Receive Time-out	0: No receive time-out error 1: Receive time-out error
7	Parity Error	0: Odd parity (no error) 1: Even parity (error)

## OUTPUT BUFFER

The output buffer is an 8-bit read-only register at I/O address hex 60. The keyboard controller uses the output buffer to send the scan code received from the keyboard and data bytes required by commands to the system. The output buffer should be read only when the output buffer full bit in the register is 1.

## ONPUT BUFFER

The input buffer is an 8-bit write-only register at I/O address hex 60 or 64. Writing to address hex 60 sets a flag that indicates a data write; writing to address hex 64 sets a flag that indicates a command write. Data written to I/O address hex 60 are sent to the keyboard (unless the keyboard controller is expecting a data byte) following the controller's input buffer only if the input buffer full bit in the status register is set to 0.

### (A) Input Port Definition (AT Mode)

BIT	FUNCTION
0	Undefined
1	Undefined
2	Undefined
3	Undefined
4	RAM on System Board 0: Disable second 256 KB of system board RAM 1: Enable second 256 KB of system board RAM



## (A) Input Port Definition (AT Mode), continued

BIT	FUNCTION
5	Manufacturing Jumper Installed 0: Manufacturing jumper 1: Jumper not installed
6	Display Type Switch 0: Primary display attached to color/graphics 1: Primary display attached to monochrome
7	Keyboard Inhibit Switch 0: Keyboard inhibited 1: Keyboard not inhibited

## (B) Output Port Definition (AT Mode)

BIT	FUNCTION
0	System Reset
1	Gate A20
2	Undefined
3	Undefined
4	Output Buffer Full
5	Input Buffer Empty
6	Keyboard Clock (Output)
7	Keyboard Data (Output)

## (C) Test-input Port Definition (AT Mode)

BIT	FUNCTION
0	Keyboard Clock (Input)
1	Keyboard Data (Input)

## Status Register (PS/2 Mode)

BIT	BIT FUNCTION	DESCRIPTION
0	Output Buffer Full	0: Output buffer empty 1: Output buffer full
1	Input Buffer Full	0: Input buffer empty 1: Input buffer full
2	System Flag	This bit may be set to 0 or 1 by writing to the system flag bit in the command byte of the keyboard controller. It is set to 0 after a power-on reset.





Status Register (PS/2 Mode), continued

BIT	BIT FUNCTION	DESCRIPTION
3	Command/Data	0: Data byte 1: Command byte
4	Inhibit Switch	0: Keyboard is inhibited 1: Keyboard is not inhibited
5	Auxiliary Device Output Buffer	0: Auxiliary device output buffer empty 1: Auxiliary device output buffer full
6	General Purpose Time-out	0: No time-out error 1: Time-out error
7	Parity Error	0: Odd parity 1: Even parity (error)

### Input Port Definition

BIT	FUNCTION
0	Keyboard Data Input
1	Mouse Data Input
2	Undefined
3	Undefined
4	RAM on System Board 0: Disable second 256 KB of system board RAM 1: Enable second 256 KB of system board RAM
5	Manufacturing Jumper 0: Manufacturing jumper 1: Jumper not installed
6	Display Type Switch 0: Primary display attached to color/graphics 1: Primary display attached to monochrome
7	Keyboard Input Switch 0: Keyboard inhibited 1: Keyboard not inhibited

### Output Port Definition

BIT	FUNCTION
0	System Reset
1	Gate A20
2	Mouse Data Output
3	Mouse Clock Output



Output Port Definition, continued

BIT	FUNCTION
4	Keyboard Output Buffer Full Interrupt
5	Mouse Output Buffer Full Interrupt
6	Keyboard Clock Output
7	Keyboard Data Output

### Test-input Port Definition

BIT	FUNCTION
0	Keyboard Clock Input
1	Mouse Clock Input

### Commands (I/O Address HEX 64) (AT Mode)

COMMAND	FUNCTION																		
20	Read Command Byte of Keyboard Controller																		
60	Write Command Byte of Keyboard Controller <table border="1" style="margin-left: 20px;"> <thead> <tr> <th>BIT</th> <th>BIT DEFINITION</th> </tr> </thead> <tbody> <tr> <td>7</td> <td>Reserved</td> </tr> <tr> <td>6</td> <td>IBM PC Compatible Mode</td> </tr> <tr> <td>5</td> <td>IBM PC Mode</td> </tr> <tr> <td>4</td> <td>Disable Keyboard</td> </tr> <tr> <td>3</td> <td>Inhibit Override</td> </tr> <tr> <td>2</td> <td>System Flag</td> </tr> <tr> <td>1</td> <td>Reserved</td> </tr> <tr> <td>0</td> <td>Enable Output Buffer Full Interrupt</td> </tr> </tbody> </table>	BIT	BIT DEFINITION	7	Reserved	6	IBM PC Compatible Mode	5	IBM PC Mode	4	Disable Keyboard	3	Inhibit Override	2	System Flag	1	Reserved	0	Enable Output Buffer Full Interrupt
BIT	BIT DEFINITION																		
7	Reserved																		
6	IBM PC Compatible Mode																		
5	IBM PC Mode																		
4	Disable Keyboard																		
3	Inhibit Override																		
2	System Flag																		
1	Reserved																		
0	Enable Output Buffer Full Interrupt																		
AA	Self-test																		
AB	Interface Test <table border="1" style="margin-left: 20px;"> <thead> <tr> <th>BIT</th> <th>BIT DEFINITION</th> </tr> </thead> <tbody> <tr> <td>00</td> <td>No Error Detected</td> </tr> <tr> <td>01</td> <td>K/B Clock Line is Stuck Low</td> </tr> <tr> <td>02</td> <td>K/B Clock Line is Stuck High</td> </tr> <tr> <td>03</td> <td>K/B Data Line is Stuck Low</td> </tr> <tr> <td>04</td> <td>K/B Data Line is Stuck High</td> </tr> </tbody> </table>	BIT	BIT DEFINITION	00	No Error Detected	01	K/B Clock Line is Stuck Low	02	K/B Clock Line is Stuck High	03	K/B Data Line is Stuck Low	04	K/B Data Line is Stuck High						
BIT	BIT DEFINITION																		
00	No Error Detected																		
01	K/B Clock Line is Stuck Low																		
02	K/B Clock Line is Stuck High																		
03	K/B Data Line is Stuck Low																		
04	K/B Data Line is Stuck High																		
AD	Disable Keyboard Feature																		
AE	Enable Keyboard Interface																		



Commands (I/O Address HEX 64) (AT Mode), continued

COMMAND	FUNCTION
C0	Read Input Port
D0	Read Output Port
D1	Write Output Port
E0	Read Test Inputs
F0-FF	Pulse Output Port

Commands (I/O Address HEX 64) (PS/2 Mode)

COMMAND	FUNCTION																		
20	Read Command Byte of Keyboard Controller																		
60	Write Command Byte of Keyboard Controller <table border="1" style="margin-left: 40px;"> <thead> <tr> <th>BIT</th> <th>BIT DEFINITION</th> </tr> </thead> <tbody> <tr> <td>7</td> <td>Reserved</td> </tr> <tr> <td>6</td> <td>IBM Keyboard Translate Mode</td> </tr> <tr> <td>5</td> <td>Disable Auxiliary Device</td> </tr> <tr> <td>4</td> <td>Disable Keyboard</td> </tr> <tr> <td>3</td> <td>Reserve</td> </tr> <tr> <td>2</td> <td>System Flag</td> </tr> <tr> <td>1</td> <td>Enable Auxiliary Interrupt</td> </tr> <tr> <td>0</td> <td>Enable Keyboard Interrupt</td> </tr> </tbody> </table>	BIT	BIT DEFINITION	7	Reserved	6	IBM Keyboard Translate Mode	5	Disable Auxiliary Device	4	Disable Keyboard	3	Reserve	2	System Flag	1	Enable Auxiliary Interrupt	0	Enable Keyboard Interrupt
BIT	BIT DEFINITION																		
7	Reserved																		
6	IBM Keyboard Translate Mode																		
5	Disable Auxiliary Device																		
4	Disable Keyboard																		
3	Reserve																		
2	System Flag																		
1	Enable Auxiliary Interrupt																		
0	Enable Keyboard Interrupt																		
A7	Disable Auxiliary Device Interface																		
A8	Enable Auxiliary Device Interface																		
A9	Interface Test <table border="1" style="margin-left: 40px;"> <thead> <tr> <th>BIT</th> <th>BIT DEFINITION</th> </tr> </thead> <tbody> <tr> <td>00</td> <td>No Error Detected</td> </tr> <tr> <td>01</td> <td>Auxiliary Device "Clock" line is stuck low</td> </tr> <tr> <td>02</td> <td>Auxiliary Device "Clock" line is stuck high</td> </tr> <tr> <td>03</td> <td>Auxiliary Device "Data" line is stuck low</td> </tr> <tr> <td>04</td> <td>Auxiliary Device "Data" line is stuck low</td> </tr> </tbody> </table>	BIT	BIT DEFINITION	00	No Error Detected	01	Auxiliary Device "Clock" line is stuck low	02	Auxiliary Device "Clock" line is stuck high	03	Auxiliary Device "Data" line is stuck low	04	Auxiliary Device "Data" line is stuck low						
BIT	BIT DEFINITION																		
00	No Error Detected																		
01	Auxiliary Device "Clock" line is stuck low																		
02	Auxiliary Device "Clock" line is stuck high																		
03	Auxiliary Device "Data" line is stuck low																		
04	Auxiliary Device "Data" line is stuck low																		
AA	Self-test																		



Commands (I/O Address HEX 64) (PS/2 Mode), continued

COMMAND	FUNCTION												
AB	Interface Test <table border="1"> <thead> <tr> <th>BIT</th> <th>BIT DEFINITION</th> </tr> </thead> <tbody> <tr> <td>00</td> <td>No Error Detected</td> </tr> <tr> <td>01</td> <td>Keyboard "Clock" line is stuck low</td> </tr> <tr> <td>02</td> <td>Keyboard "Clock" line is stuck high</td> </tr> <tr> <td>03</td> <td>Keyboard "Data" line is stuck low</td> </tr> <tr> <td>04</td> <td>Keyboard "Data" line is stuck high</td> </tr> </tbody> </table>	BIT	BIT DEFINITION	00	No Error Detected	01	Keyboard "Clock" line is stuck low	02	Keyboard "Clock" line is stuck high	03	Keyboard "Data" line is stuck low	04	Keyboard "Data" line is stuck high
BIT	BIT DEFINITION												
00	No Error Detected												
01	Keyboard "Clock" line is stuck low												
02	Keyboard "Clock" line is stuck high												
03	Keyboard "Data" line is stuck low												
04	Keyboard "Data" line is stuck high												
AD	Disable Keyboard Interface												
AE	Enable Keyboard Interface												
C0	Read Input Port												
C1	Poll Input Port Low												
C2	Poll Input Port High												
D0	Read Output Port												
D1	Write Output Port												
D2	Write Keyboard Output Buffer												
D3	Write Auxiliary Device Output Buffer												
D4	Write to Auxiliary Device												
E0	Read Test Inputs												
F0-FF	Pulse Output Port												

## AC TIMING

NO.	DESCRIPTION	MIN.	MAX.	UNIT
T1	Address Setup Time from WRB	0		nS
T2	Address Setup Time from RDB	0		nS
T3	WRB Strobe Width	20		nS
T4	RDB Strobe Width	20		nS
T5	Address Hold Time from WRB	0		nS
T6	Address Hold Time from RDB	0		nS
T7	Data Setup Time	50		nS
T8	Data Hold Time	0		nS
T9	Gate Delay Time from WRB	10	30	nS



## AC Timing, continued

NO.	DESCRIPTION	MIN.	MAX.	UNIT
T10	RDB to Drive Data Delay		40	nS
T11	RDB to Floating Data Delay	0	20	nS
T12	Data Valid After Clock Falling (SEND)		4	μS
T13	K/B Clock Period	20		μS
T14	K/B Clock Pulse Width	10		μS
T15	Data Valid Before Clock Falling (RECEIVE)	4		μS
T16	K/B ACK After Finish Receiving	20		μS
T17	RC Fast Reset Pulse Delay (8 MHz)	2	3	μS
T18	RC Pulse Width (8 MHz)	6		μS
T19	Transmit Timeout		2	mS
T20	Data Valid Hold Time	0		μS
T21	X1/X2 Period (6–12 MHz)	83	167	nS
T22	Duration of CLK inactive	30	50	μS
T23	Duration of CLK active	30	50	μS
T24	Time from inactive CLK transition, used to time when the auxiliary device sample DATA	5	25	μS
T25	Time of inhibit mode	100	300	μS
T26	Time from rising edge of CLK to DATA transition	5	T28-5	μS
T27	Duration of CLK inactive	30	50	μS
T28	Duration of CLK active	30	50	μS
T29	Time from DATA transition to falling edge of CLK	5	25	μS
T30	Mode detect signal after P10 goes high	Typical 1 mS		
T31	High pulse of mode detect signal	Typical 220 μS		
T32	Low pulse of mode detect signal	Typical 220 μS		
T33	Mode detect signal after RESET goes high	Typical 1 mS		
T34	Time out of AT mode' s mode detect signal	Typical 64 mS		



**TIMING WAVEFORMS**

**Write Cycle Timing**

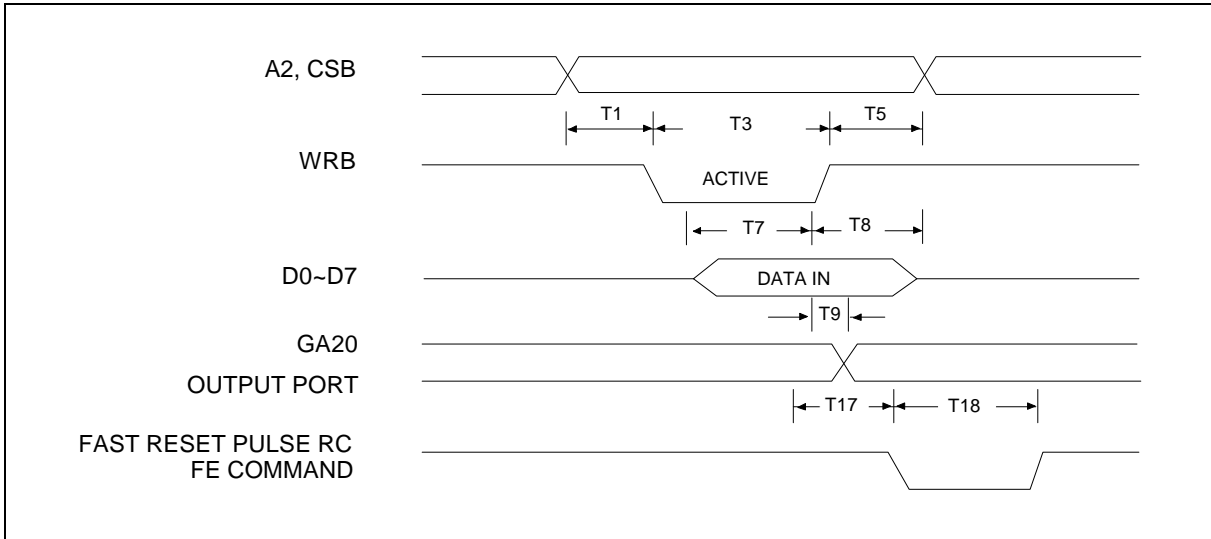

**Read Cycle Timing**

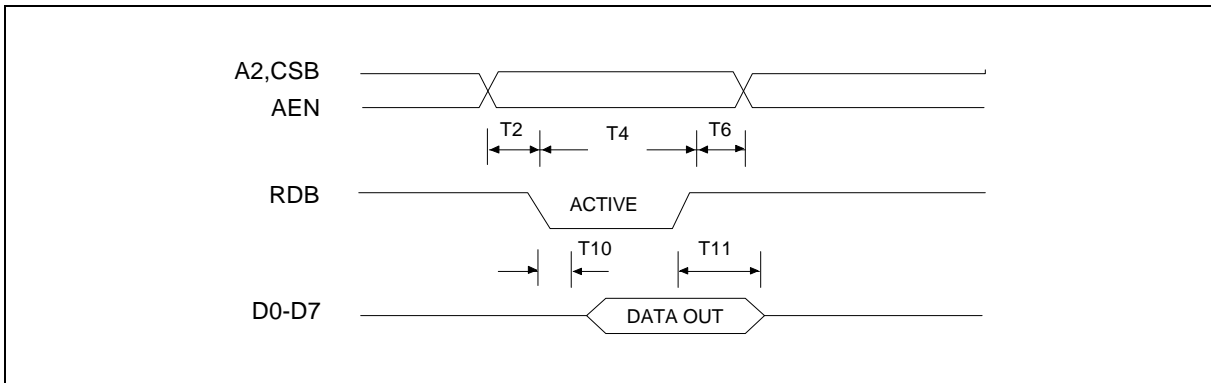

**Send Data to K/B**

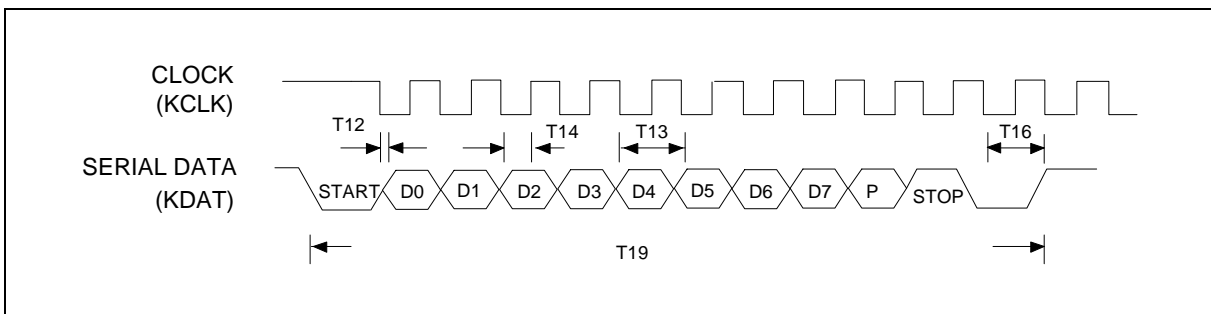



**Receive Data from K/B**

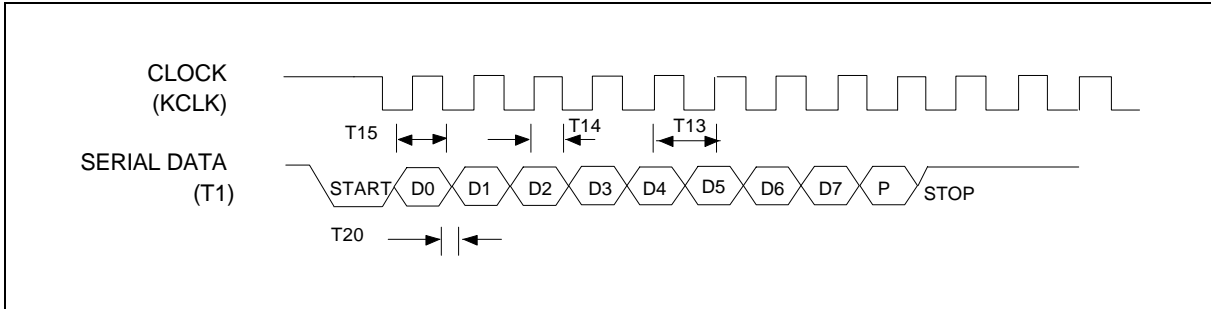

**X1/X2 Clock**

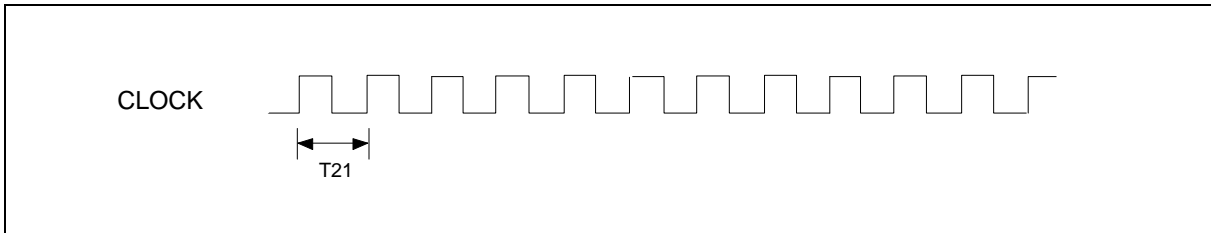

**Send Data to Mouse**

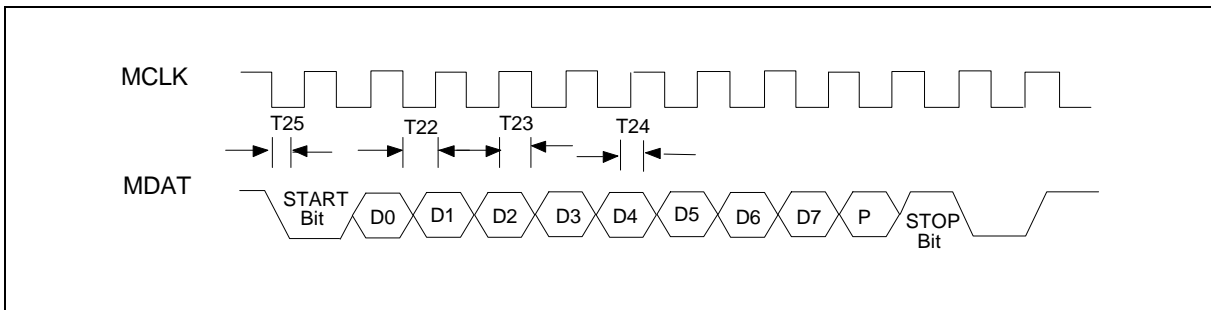

**Receive Data from Mouse**

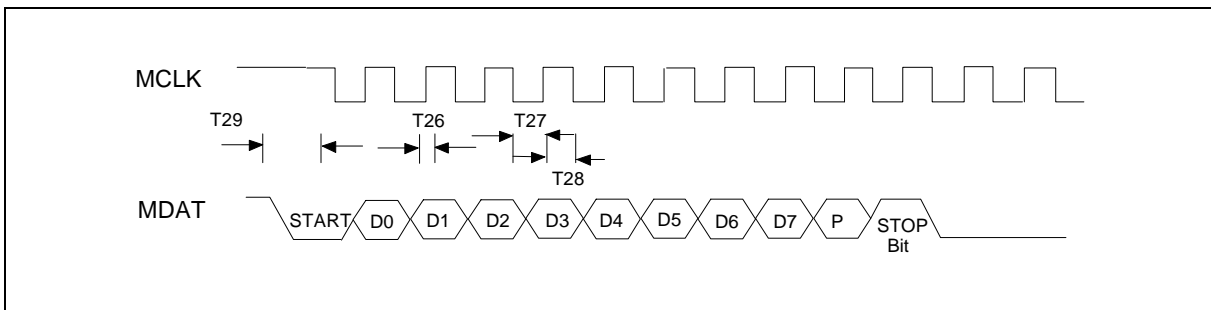



**PS2 Mode's Mode Detect**

(P10 released to high by keyboard before RESET goes high)

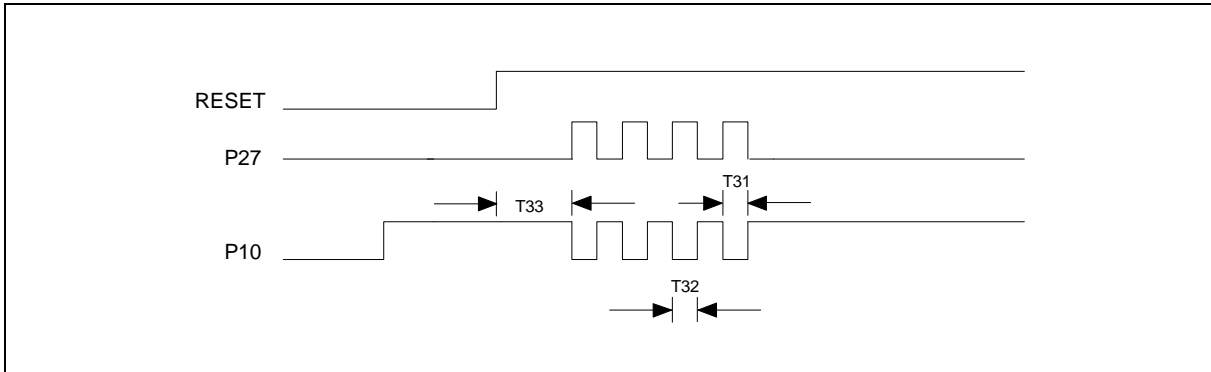

**PS2 Mode's Mode Detect**

(P10 released to high by keyboard after RESET goes high)

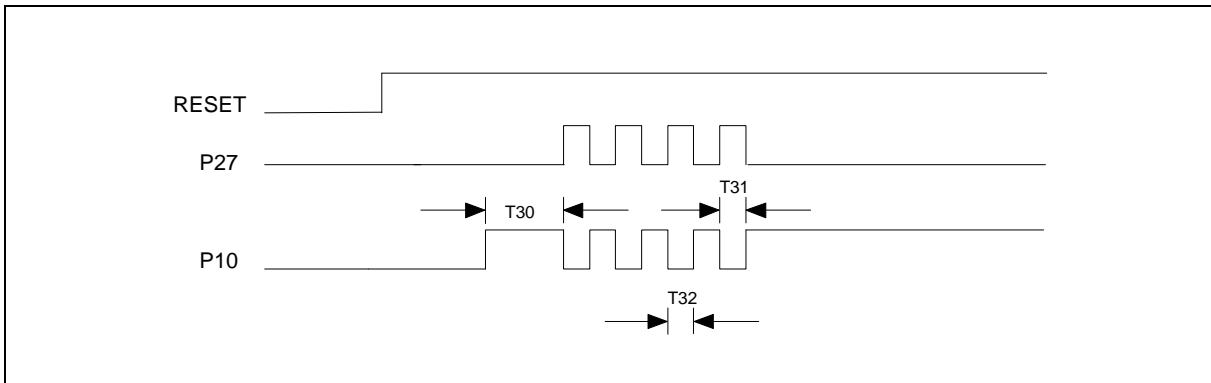

**AT Mode's Mode Detect**

(P10 internal pull high. As there is no external loop between P27 and P10 so P27 issues pulse until time out )

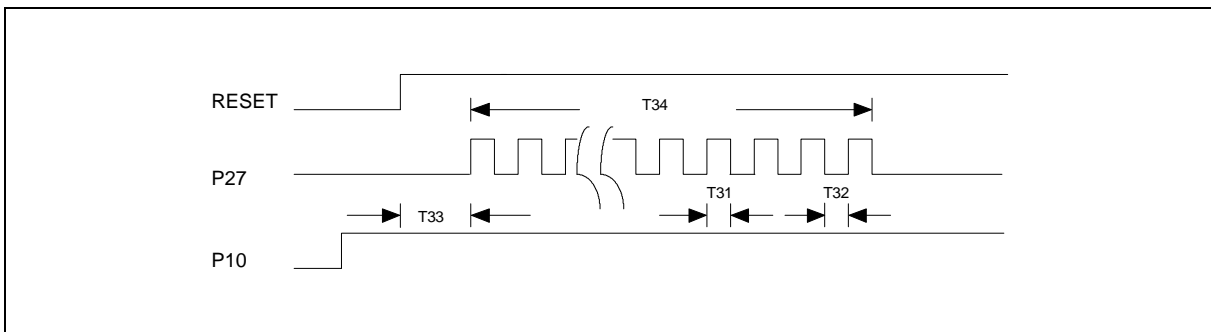



## TYPICAL APPLICATION CIRCUITS

### Application for AT Mode

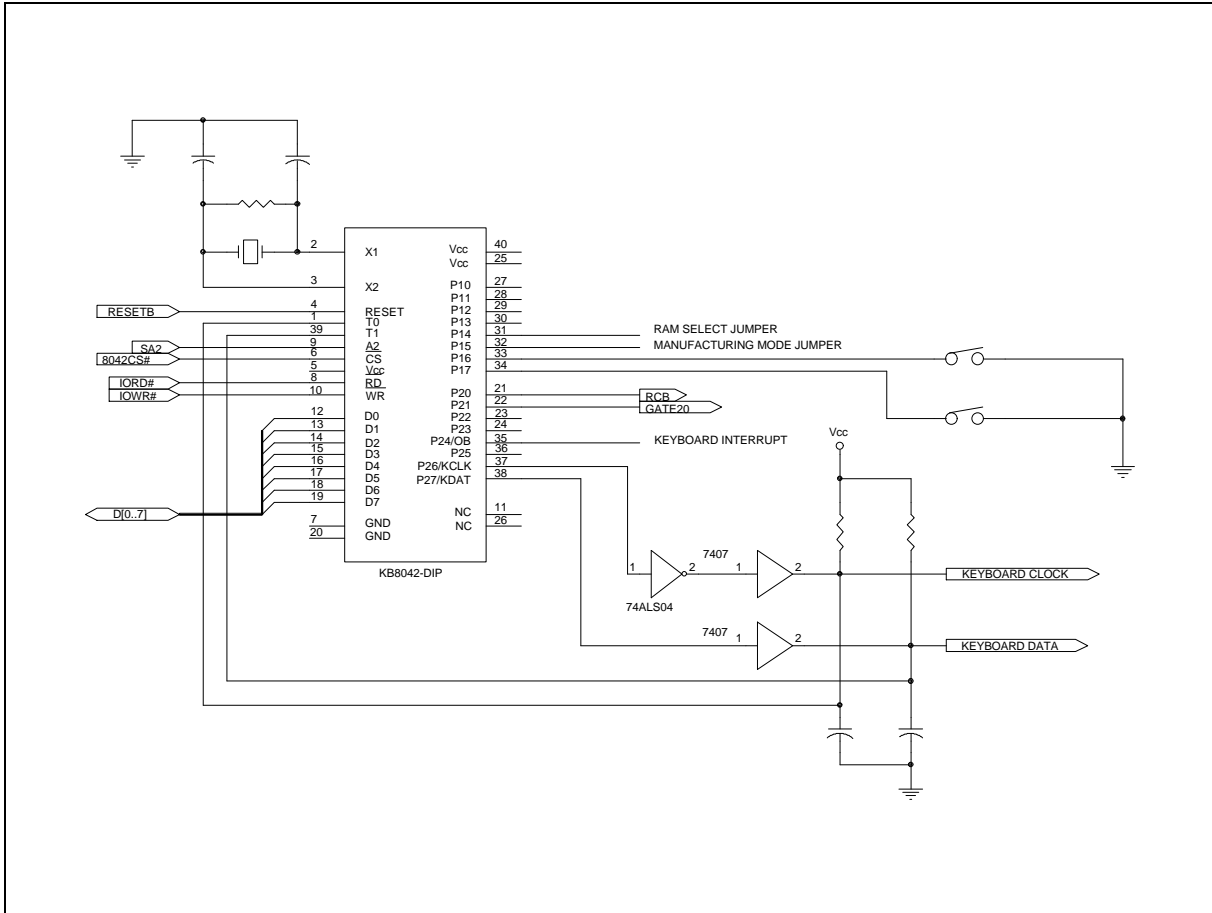

## Application for PS/2 Mode

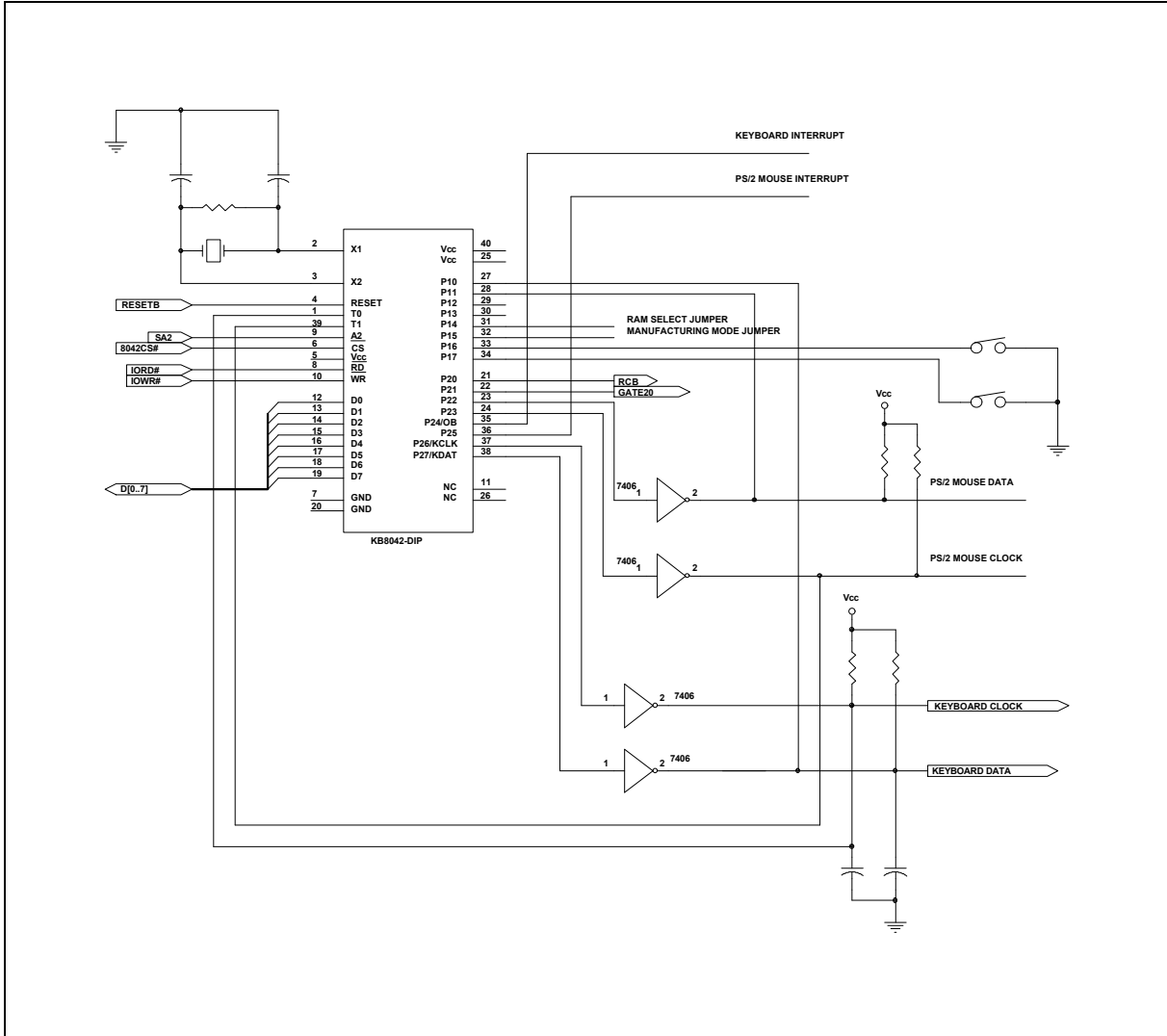

Driving from External Source

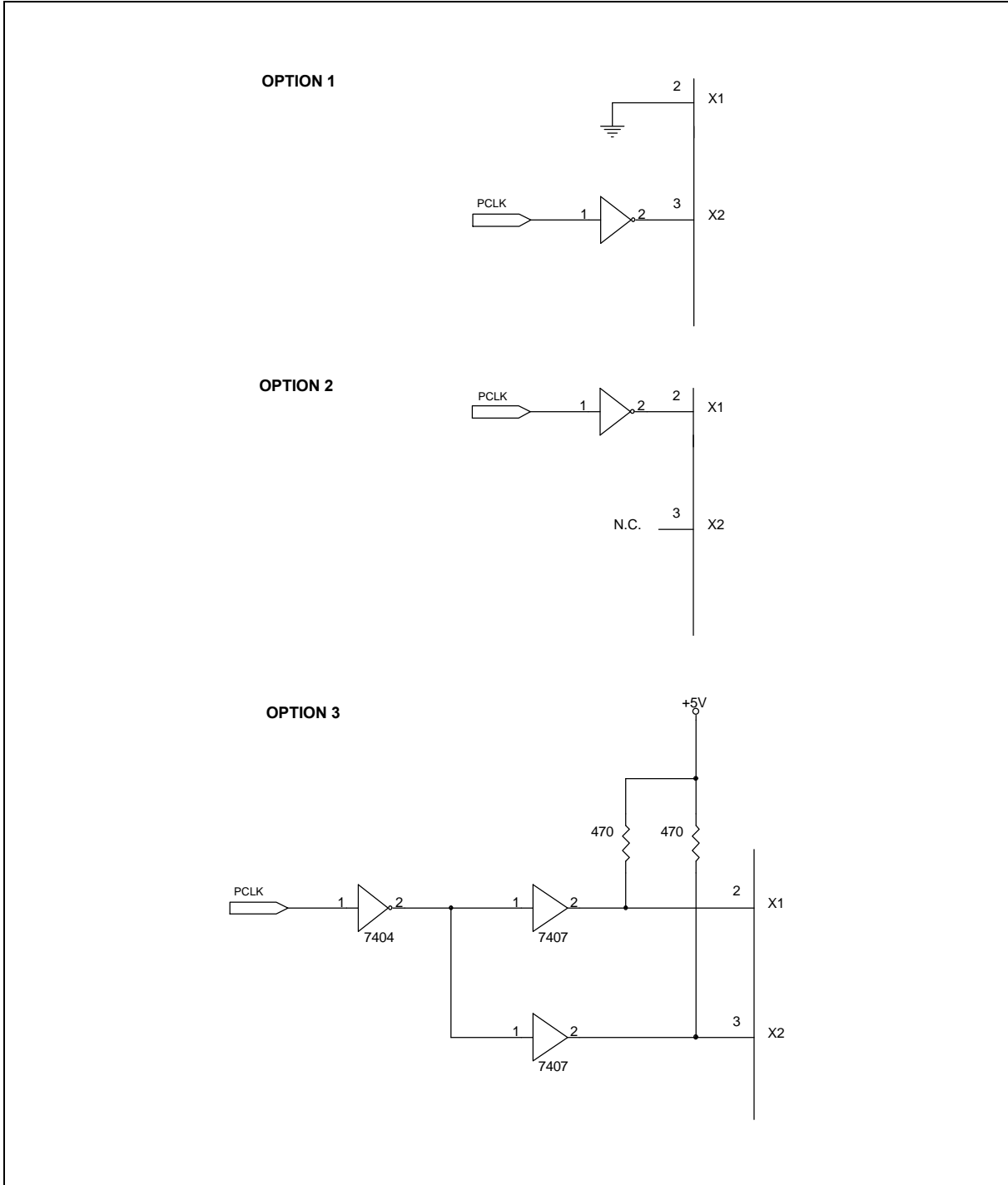

## PACKAGE DIMENSIONS

### 40-pin DIP

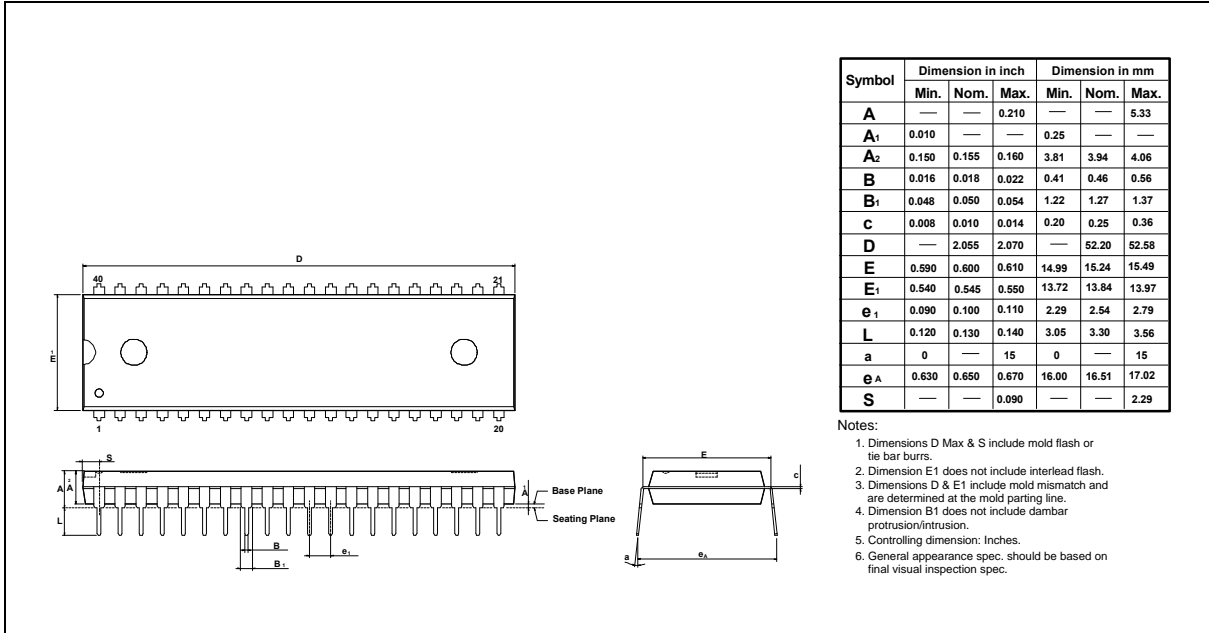

### 44-pin PLCC

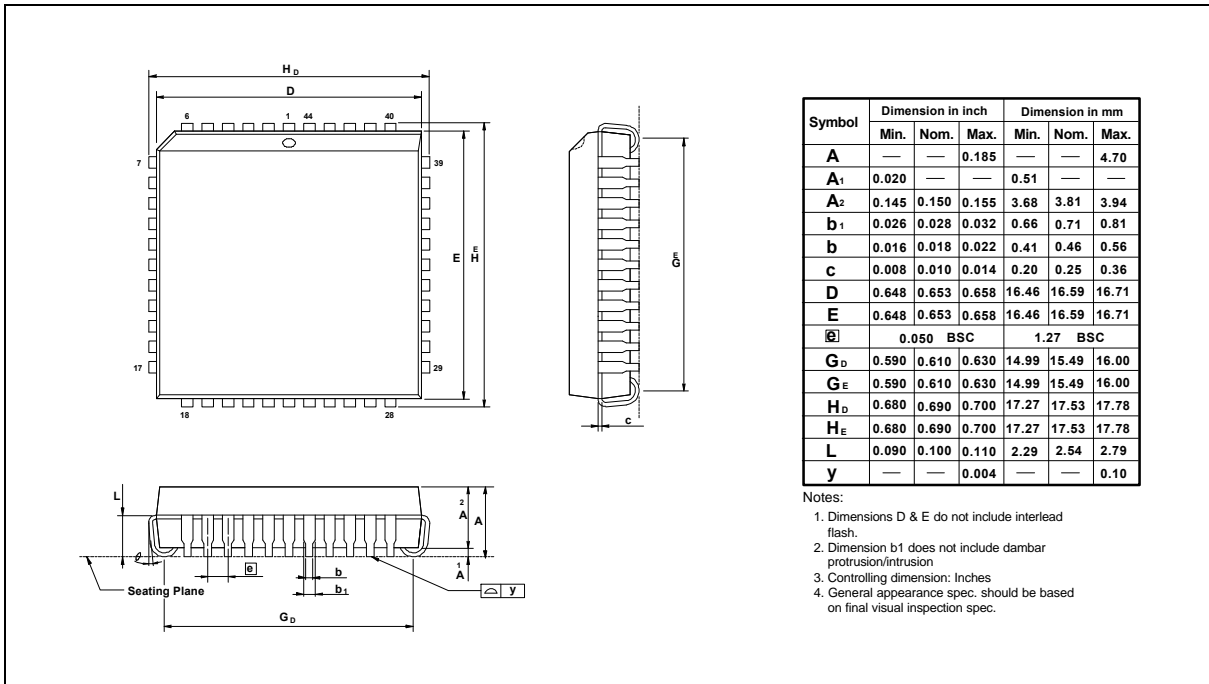



#### Headquarters

No. 4, Creation Rd. III,  
Science-Based Industrial Park,  
Hsinchu, Taiwan  
TEL: 886-3-5770066  
FAX: 886-3-5792646  
<http://www.winbond.com.tw/>  
Voice & Fax-on-demand: 886-2-7197006

#### Taipei Office

11F, No. 115, Sec. 3, Min-Sheng East Rd.,  
Taipei, Taiwan  
TEL: 886-2-7190505  
FAX: 886-2-7197502

#### Winbond Electronics (H.K.) Ltd.

Rm. 803, World Trade Square, Tower II,  
123 Hoi Bun Rd., Kwun Tong,  
Kowloon, Hong Kong  
TEL: 852-27516023  
FAX: 852-27552064

#### Winbond Electronics North America Corp.

Winbond Memory Lab.  
Winbond Microelectronics Corp.  
Winbond Systems Lab.  
2730 Orchard Parkway, San Jose,  
CA 95134, U.S.A.  
TEL: 1-408-9436666  
FAX: 1-408-9436668

Note: All data and specifications are subject to change without notice.